

Solar solutions Safety in PV installations



With over 30 years of experience in the Australian electrical industry, DKSH have created a best in class solar portfolio from Europe's world leading manufacturers. Our partnership with Multi-Contact, Lapp Kabel, Wieland Electric and ABB has enabled us to be involved in the solar industry in Australia for over a decade.

Over the years we have seen many new products arrive on the market, and have some serious concerns about the quality of some of these items. When you design a system that should last 25 years, there is no excuse for using sub standard components. In fact the difference between using inferior products and premium products could be as little as \$10 - \$20 (total) on a \$15,000 PV installation.

We have seen Multi-Contact's MC3 and MC4 connectors copied, some copies are very poor quality and although they may work for the first year or two of an installation, serious concerns have been raised about not only the electrical connections, but also the materials they have been made from. As these connectors fail, property and life could be put at risk.

Recently sub standard DC rated circuit breakers have started to enter the market, and we have heard stories of failures at the time of installation. Some installations have had AC rated product installed. AC rated isolators are common, so too is using domestic grade flexible conduits.

Some multi-string installations have used AC fuses, or worse still, they have used polarized DC circuit breakers. In the event of a reverse current fault, a standard polarised DC circuit breaker will offer no protection, and could actually catch fire as the arc extinguishment chamber is designed to work in one direction only. DC fuses designed specifically for PV installations or non-polarised DC circuit breakers are the only products that can be used for this application.

Cable choice should be a major consideration on a PV installation. When you are dealing with 1kW or more of DC power, you should be using a cable that not only has the correct voltage rating, but also the right mechanical construction. The use of TPS for running DC should be looked at with great concern. This cable was originally designed for AC circuits, and could easily be mistaken for an AC cable in a dark rooftop, even if it does have a hand written label on it. Appropriately labelled SDI or TWIN SDI cables should be used for easy identification and to maximise mechanical protection. These cables should be flexible to reduce the risk of damage to the conductors at the time of installation, and the conductors should be tinned to lower the risk of corrosion and poor connections over an extended period of time. DKSH raised these concerns about installers using TPS for solar cabling with our German partner Lapp Kabel and together we designed the TWIN SDI cable specifically for Australian solar installations. There is no longer any reason to use TPS or non solar specific cables for DC cabling in and on Australian roof spaces.

Not only poor product choice, but also poor work practices in the last few years from some businesses have seen substandard installations carried out and customers not receive the quality they are expecting. We have spoken to numerous installation companies and can't believe the excuses given for cutting corners to save a few cents.

Our concern for the safety of PV installations in Australia has led us to compile this publication with articles and products which leave no more reason for sub standard installations. All of these items are designed and rated for specific applications and are all of the highest quality, from well established, world leading European manufacturers.

We ask that you spend the time to read these articles, and the next time you carry out an installation and you are deciding which products to install, ask yourself, "Would I want to use this product on my family home?"



David Faux
Product Manager - Solar
DKSH Australia Pty Ltd

Safety concerns on the use of counterfeit connectors

A growing number of suspect copies of Multi-Contact's world renowned MC Solar components have recently appeared on the market. Comparative measurements and material tests have revealed substantial deficiencies in quality, and compromised safety and system performance.

Visually, the copies are virtually indistinguishable from the genuine MC products. Multi-Contact is defending itself on the one hand by taking court action against the imitators and on the other hand by increasing awareness to protect you and your customers from the financial and reputational damage that can result from the use of inferior products. Concerns have been highlighted about the safety characteristics such as UV-resistance, contact resistance, and material quality, that may be dangerous when installed in a PV system.

The serious problems which result from inadequate compatibility or the use of inferior copies frequently occur only after a considerable period of time has elapsed. The use of poorly matched connectors can cause contact problems that can directly or indirectly lead to a marked rise in the temperature of the plug connector due to a higher contact resistance. This can subsequently result in arcing and ultimately to a fire. This can lead to substantial damage to your professional reputation, loss of revenue from the PV system, material damage, and quite possibly personal injury.

Using copies mated with the genuine Multi-Contact connectors can result in a poor fit between insulator parts that can result in system failure due to compromised sealing against the elements such as rain or dust.



How can you recognise the genuine products?

As a result, the insulating properties are no longer assured and a person touching the connector may be electrocuted.

For your safety, we do not recommend using inferior copies, as the mating forces, plating materials and insulation properties cannot be guaranteed. Effects such as fretting corrosion may be caused by incompatible plating materials, contact forces and other influences. In order to avoid such adverse effects, the contacts and insulating parts of the connectors must have compatible properties. Tests of such properties are time-consuming and are not covered by certification tests.

Multi-Contact has been involved in the solar industry with their high quality plug connector systems for photovoltaic installations for more than 10 years, and has gained considerable experience on the long-term behavior of millions of plug connectors.

Inferior copies can be disastrous, potentially resulting in overheated connectors and cables which has dangerous consequences. As an installer or OEM, you guarantee your system for 20 years or more, therefore don't risk it, for the sake of saving a few cents in the overall cost of an installation, always ask for, and demand the genuine Multi-Contact MC connector.

If you have any concerns about the authenticity of the product you are currently using or being supplied, please contact Multi-Contact's partner in Australia, DKSH, on 1800 010 113 to confirm if the product you are using is a genuine MC connector.

Differences in quality



Original MC connectors and others

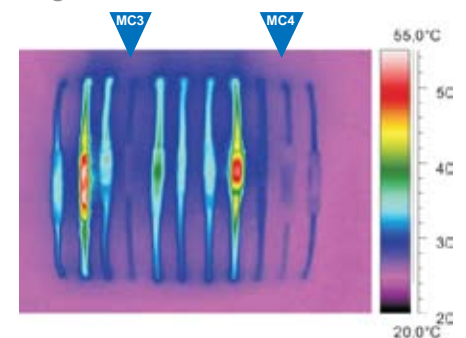

A temperature increase test by the TÜV Rheinland with PV plug connectors from various manufacturers shows significant differences in the rise in temperature and the excellent results of MC-PV connectors.

440/500V DC circuit breakers

Maximum safety for use in photovoltaic systems

ABB's well established System proM S280 range of MCBs (miniature circuit breakers) has been further extended to include UC (Universal Current versions) which feature the K tripping characteristic which is the optimal solution for the safe protection of cables. A permanent magnet assists in the forced extinguishing of the DC arc.

Rated voltage:

- 440V

Maximum operating voltage:

- 500V

Current rating (A)	Icn (kA)	2 pole 440/500V DC
6	6	S282UCK6
8	6	S282UCK8
10	6	S282UCK10
16	6	S282UCK16
20	6	S282UCK20
25	6	S282UCK25
32	6	S282UCK32
40	6	S282UCK40

Locking device:

Prevents unauthorized operation of the operating lever. Suits 3mm Ø padlock

Part number: SA1



800V DC circuit breakers

Maximum safety for use in photovoltaic systems

The high-performance MCB S800PV-S specially developed for use in photovoltaic systems offers reliable protection for PV modules and lines against reverse currents from defective strings and AC regenerative feedback due to defective inverters.

The high demands of PV systems have been taken into consideration in the development of the S800PV-S:

More comfort:

Disconnecter properties for comfortable switching even under load.

More voltage:

Higher nominal voltage range up to 1200VDC (3 pole). Rated continuous current up to 125A.

More accessories:

Wide range of accessories, for example for remote switching, fault signalling and external driving.

More space:

Highly compact dimensions for space-saving installation on the DIN rail.

Non Polarised:

Polarity independent design, can be used for string protection.

Locking device:

Prevents unauthorized operation of the operating lever. Suits 4mm Ø padlock



Part number: S800-PLL

Current rating (A)	Icu (kA)	2 pole 800V DC	3 pole 1200V DC
10	5	S802PVS10	S803PVS10
13	5	S802PVS13	S803PVS13
16	5	S802PVS16	S803PVS16
20	5	S802PVS20	S803PVS20
25	5	S802PVS25	S803PVS25
32	5	S802PVS32	S803PVS32
40	5	S802PVS40	S803PVS40
50	5	S802PVS50	S803PVS50
63	5	S802PVS63	S803PVS63
80	5	S802PVS80	S803PVS80
100	5	S802PVS100	S803PVS100
125	5	S802PVS125	S803PVS125



ABB protection devices

Component supplier for residential and power plant application

ABB has been working for many years, as both a manufacturer and supplier, to offer products and solutions that reduce the environmental impact of energy systems. In a world of ever diminishing resources and soaring energy demand, the focus of ABB's research lies in developing efficient and sustainable ways to generate, transmit, distribute and use electrical energy.

With vast experience in Automation Products, ABB is constantly searching for new ways to expand and enhance existing technologies to meet the needs of its customers. In a society where climate change is becoming an ever stronger argument for increased use of clean energy, such as wind or solar power.

ABB represents the best supplier for OEMs, installers and general contractors, offering a complete portfolio of products to support development of the renewable energy market. For the photovoltaic market, ABB supplies a comprehensive range of high technology products for virtually every residential, commercial and power plant application to grant its customers access to renewable sources of energy.

An investment in a solar plant is an investment in and for the future. The profitability calculation derived from the amount invested, term of financing and amortisation is based on factors such as the size and output of the system, climatic conditions and the general conditions arising from the geographical/regional installation location.



Although the risk presented to the systems by lightning, over- and reverse currents and overvoltage can be defined statistically, there are always elements of uncertainty. Therefore, ABB sees integrated solutions for overvoltage protection as an absolute prerequisite. These take the form of tried-and-tested components which ensure that the level of income corresponds to the forecasts for your development.

Lightning and overvoltage protection

Protection devices for PV installations

Cells and inverters are very sensitive to overvoltage and impulse currents, such as switching and lightning surges. The ABB surge arrester range for special DC limits the overvoltage to an acceptable level for the equipment to be protected and prevent damage to installations. Therefore, the risk of financial losses should be taken into account when considering an investment in solar panels. One of the benefits of using SPDs is a better return on investment.



Location	Type	Role	Options	Comment
A	DC	Protection of cells	If the distance L1 < 10 m, only OVR PV in A or B is recommended.	Connection to the chassis should be as short and rectilinear as possible. The lightning arrester depending on the environment should be installed in a leak-proof casing.
B	DC	Protection of the inverter input on the DC side	If the distance L1 < 10 m, only OVR PV in A or B is recommended.	Connection to the earthing bar and to the ground of the inverter on the DC side should be as short and rectilinear as possible.
C	AC	Protection of the inverter output on the AC side	Routine installation	Connection to the earthing bar and to the ground of the inverter on the AC side should be as short and rectilinear as possible.
D	AC	AC head protection at the entrance of the building	Routine installation	Connection to the earthing bar should be as short and rectilinear as possible.

Solar Cable Selection Guide

		Lapp Olflex Solar XLS	Lapp V90HT TWIN	Thermo Plastic Sheath (TPS)
Cable Construction	Conductor	Material Stranding	Tinned Copper Class 5 Flexible	Tinned Copper Class 5 Flexible
	Insulation	Material	Electron beamed X-linked polyolefin	PVC (V90HT)
Technical data	Sheath	Material	Electron beamed X-linked Co-polymer	PVC (V90HT)
		Nominal Voltage AC	600/1000V	600/1000V
		Nominal Voltage DC	900/1500V	900/1500V
Application Criteria		Weather Resistance	Excellent	Good
		UV Resistance	Excellent	Excellent
		Flexibility	Excellent	Excellent
		Abrasion Resistance	Excellent	Good
		Halogen Free	Yes	No
		Ammonia Gas Resistance	Excellent	Not Tested
		Thermal Endurance Test	Excellent	Not Tested
		Damp heat resistance test EN60068-2-78 with 85% humidity	Excellent	Not Tested
		Labeled for Solar application	Yes	Yes
		Designed specifically for Rooftop wiring from PV modules	DC Solar - PV modules to inverter	DC Solar - wiring from rooftop to inverter
Notes		Yes	Yes	AC circuit wiring
		Yes	Yes	No
		Yes	Yes	Not Recommended

Olflex® Solar XLS

Cross-linked standard solar cable

Description:

Constructed using class 5, fine stranded tinned copper conductors, and insulated with cross-linked copolymer compound and protected by an outer sheath of black, UV resistant, halogen-free cross-linked copolymer.

Benefits:

- Reduced spreading of fire source and formation of toxic combustion gases in event of fire
- Exact quantity control during installation by meter marking on the cable sheath

Features:

- Weathering, abrasion, and UV resistant
- Good heat pressure resistance
- Halogen-free and flame retardant
- Resistant against ammonia and biogases, oxalic acid, sodium hydroxide, and other chemical media
- 900/1500 V DC



Part number	Nominal conductor area mm ²	Approx overall Ø mm	Stranding	Inner sheath	Outer sheath	Roll size mtrs
0025805	2.5	5.4	50 x 0.25	BLACK	BLACK	100 - 500
0025806	2.5	5.4	50 x 0.25	RED	BLACK	100 - 500
0025810	4	6.0	56 x 0.30	BLACK	BLACK	100 - 500
0025811	4	6.0	56 x 0.30	RED	BLACK	100 - 500
0025815	6	7.1	84 x 0.30	BLACK	BLACK	100 - 500
0025816	6	7.1	84 x 0.30	RED	BLACK	100 - 500
0025820	10	8.9	80 x 0.40	BLACK	BLACK	100 - 500
0025821	10	8.9	80 x 0.40	RED	BLACK	100 - 500
0025825	16	9.8	128 x 0.40	BLACK	BLACK	100 - 500
0025826	16	9.8	128 x 0.40	RED	BLACK	100 - 500

Note: Please add "S" to the end of the part number to receive 100 mtr rolls, i.e. 0025810S = 4mm² 100mtr roll

V90HT twin SDI

Economical UV resistant twin cable



Description:

An economical tinned twin core, double insulated black UV resistant flexible cable with red and blue inner cores for identification of longer runs.

Features:

- Class 5 tinned
- UV resistant
- PVC/PVC TWIN
- Black outer sheath
- 900/1500 V DC
- Blue and red inner

Australian standards:

AS5033 states that PV cables are to be clearly identified so they cannot be mistaken for power cables. This cable meets that requirement without the need for additional labelling.

Cable marking:

Caution: DC cable - Do not disconnect under load.

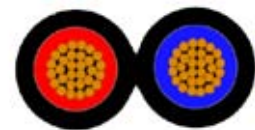

Part number	Nominal conductor area mm ²	Dimensions mm	Stranding	Outer sheath	Roll size mtrs
3803590	2.5	12.2 x 5.1	50 x 0.25	BLACK	100 - 500
3803591	4	13.8 x 5.9	56 x 0.30	BLACK	100 - 500
3803592	6	15.0 x 6.5	84 x 0.30	BLACK	100 - 500
3803593	10	16.7 x 8.3	80 x 0.40	BLACK	100 - 500

Also available in other conductor sizes, minimum order quantities apply

PV Fuse Warning - Incorrectly using AC fuses in DC circuits

Not all fuses are created equally. Using the incorrect fuse in the wrong circuit could have potentially disastrous consequences to equipment and people.

Why use a fuse?

A fuse is an overcurrent device that is designed to sacrifice itself to protect electrical systems. Fuses are designed to open circuits when put under stress by excessive current flow caused by overloads or faults.

Choosing the right fuse for the application will prevent fires and other damage caused when something goes wrong. Typical problems may include: a cable coming loose in the inverter circuit, a cable shorting to Earth, accidental cutting of a cable, an animal chewing through cabling, or weather damage.

Fuse Ratings

Fuses are rated by current, and voltage and are usually rated solely for AC, solely for DC or rated for both AC and DC. If the incorrect fuses are used for DC applications the voltage rating may need to be derated and you would have to consult the fuse manufacturer for further information on their product. This is because of the greater arc energy that needs to be absorbed during the breaking process.

The difference between AC and DC fuses

Alternating currents are quite simple for a fuse to break as the alternating current source reverses the flow of electrons 100 times a second on 50Hz circuits. When the current reverses, it goes to zero in magnitude. A zero current flow is very easy for a fuse to interrupt – at this point, the current flow has stopped and there is no longer any energy to sustain the arc



across the melted fuse element. Direct currents, on the other hand can be very difficult to break. As the name implies, the current flows in a constant direction. There is no zero point to aid the fuse in extinguishing the arc. DC fuses are relatively sophisticated devices that have a different construction to simple AC fuses, DC fuses contain additional elements to extinguish the arc.

For AC and DC fuses, the standard rated voltages are different and there is no strict mathematical relationship between them. A fuse rated at 500V AC may be rated at 250V DC or 440V DC, dependant on construction. As a general rule of thumb, a standard AC fuse will need to be derated by 50% i.e. 500V AC would be rated at 250V DC, however you should consult the fuse manufacturer for the test results or further specifications on each fuse before making any assumptions.

AC fuses are generally designed to take a load in excess of their rated current, sometimes 160-200% of their rated value for up to 10 seconds. Within a PV system, current is limited by the constant

current source design of the PV modules, obtaining enough current to break an AC rated fuse in a reasonable amount of time could be quite difficult.

DC rated fuses designed specifically for PV applications are designed to break at the rated current in a short time, providing maximum protection for cabling, junction boxes and PV modules.

If the fuse product does not state the DC rating on the fuse or on the product specification sheet then it could be that it is not approved for use in DC applications, that the product has not been approved by an internationally recognized electrical approval body or by the manufacturer who may or may not have the testing facilities to conduct the product test. Fuse holders should also be inspected for a DC rating. To protect yourself and your customers, always use the correct DC rated product for your PV installations, if you use an incorrectly rated product, you could be liable for any damage caused or loss of life, in the event of something going wrong. AS/NZS 5033-2005 states that fuses used in a PV array shall be rated for DC use.

DC Fuses

PCF10 fuse disconnectors are DIN mountable fuse carriers, to suit 10x38mm fuses, and are rated at 1000V DC and ideal for use in PV installations.

Voltage and Rating:

690VAC (32A)
1000VDC (20A)
900VDC (25A)

Cable size max:

0.5 to 10mm²/AWG 8 - 20 (solid)

Features:

Multi-pole versions can be assembled on site.

Options:

1 and 3 pole also available with neutral. Class CC versions also available for North American standard fuses.

Characteristics:

AC-22B, DC-20B

Approvals:

IEC60947-1, IEC 60947-3, EN60947-1, EN60947-3

Part number	Description
PCF10DCP1	1 pole carrier
PCF10DCP2	2 pole carrier
PCF10DCP3	3 pole carrier
PCF10DCP1S	1 pole carrier and LED indicator
PCF10DCP2S	2 pole carrier and LED indicator
PCF10DCP3S	3 pole carrier and LED indicator
PCF10P2KIT	2 pole clip and pin kit
PCF10P3KIT	3 pole clip and pin kit



Due to increasing demand for clean power, solar panel systems have rapidly improved, thereby accelerating the demand for high-performance fuse links.

These fuse links have been designed specifically for protecting PV strings.



Part number	Rating
PV3A10F	3 A 1000V DC
PV4A10F	4 A 1000V DC
PV6A10F	6 A 1000V DC
PV8A10F	8 A 1000V DC
PV10A10F	10 A 1000V DC
PV12A10F	12 A 1000V DC
PV15A10F	15 A 1000V DC
PV20A10F	20 A 1000V DC

PV fuse ambient temperature derating

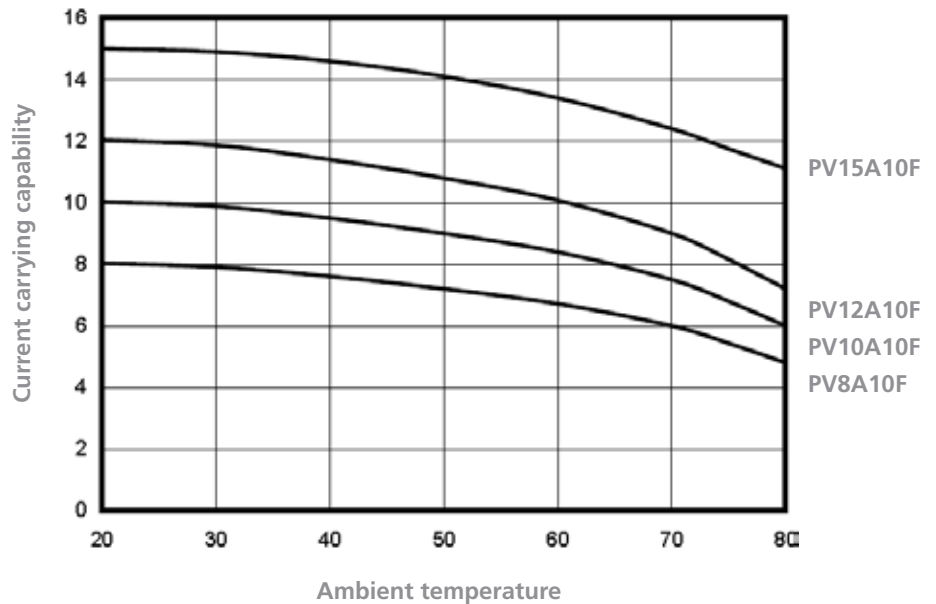

String Protection



As PV system designs become larger to maximize return on investments, the need for PV string protection is becoming more common.

We are proud to announce the release of a new string protection system. Available in numerous current ratings, these PV String Fuse Boxes are manufactured with premium components. Fusing is rated at 1000V DC and designed specifically for PV systems.

Most DC rated circuit breakers are polarised and are not suitable for string protection, therefore fusing is required.

No more need to spend hours in the workshop building these units when you could invest your time in more profitable exercises.

Benefits

- Genuine MultiContact MC4 connectors
- 1000V DC rated fuses
- 0.6/1kV Lapp cabling
- Available in numerous configurations
- Plug and play
- Unit is supplied complete
- One, Two and Three string designs
- Custom versions also available

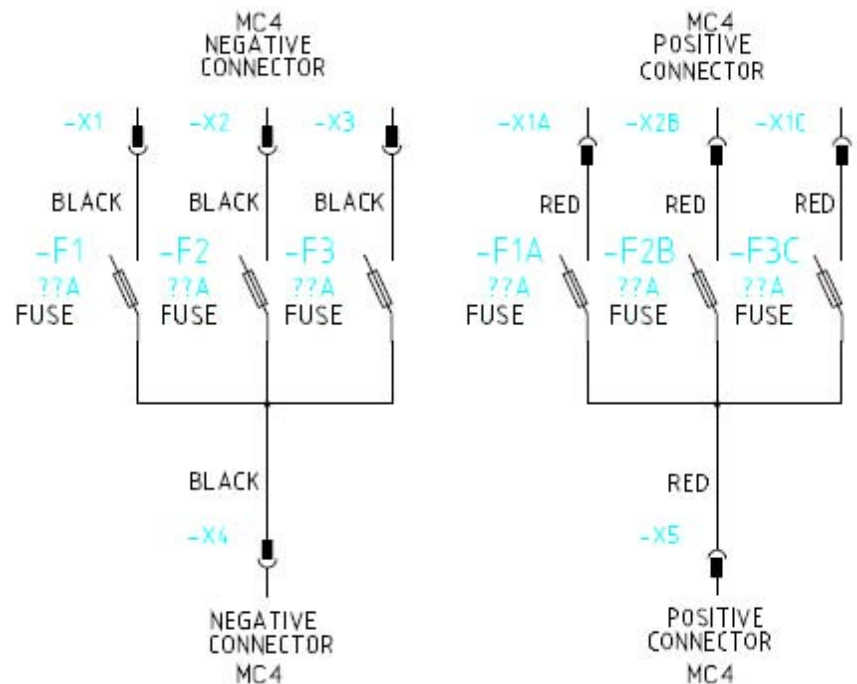
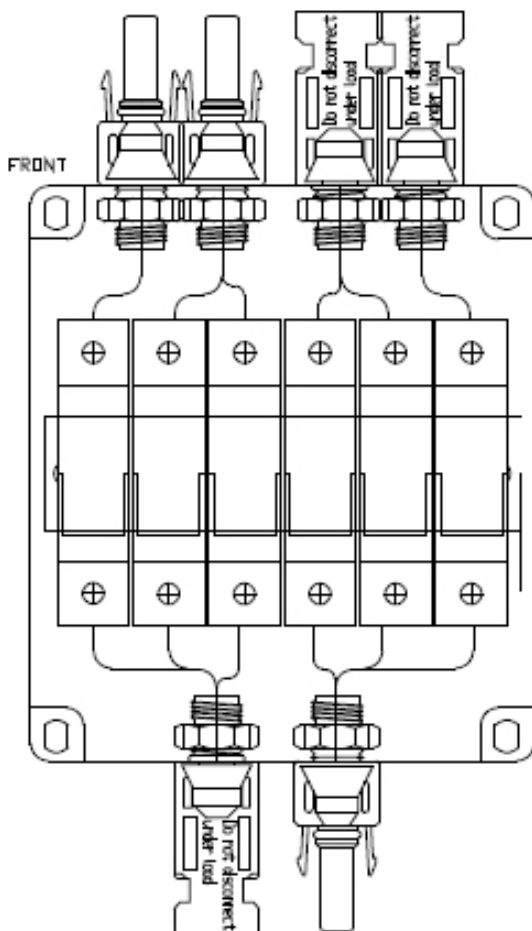

Current rating (A)

	1 String Fuse Box	2 String Fuse Box	3 String Fuse Box
4A	XPMC4FUSE1/4A	XPMC4FUSE2/4A	XPMC4FUSE3/4A
6A	XPMC4FUSE1/6A	XPMC4FUSE2/6A	XPMC4FUSE3/6A
8A	XPMC4FUSE1/8A	XPMC4FUSE2/8A	XPMC4FUSE3/8A
10A	XPMC4FUSE1/10A	XPMC4FUSE2/10A	XPMC4FUSE3/10A
12A	XPMC4FUSE1/12A	XPMC4FUSE2/12A	XPMC4FUSE3/12A
15A	XPMC4FUSE1/15A	XPMC4FUSE2/15A	XPMC4FUSE3/15A

Liquid tight IP 68 conduit



ROHRflex® PA6

Industrial standard conduit

Application:

Due to the long life span of PV arrays, Industrial grade conduit should be used to maximise the life of your installation, don't risk domestic or commercial grade conduit on PV installations.

Construction:

Internally and externally corrugated PA6 plastic tubing.

Temperature range:

-30°C to +100°C

Colour:

Black.

Protection class:

Conduit: IP68
Fittings: IP65 - IP67

Properties:

- Oil resistant up to + 80° C
- Benzene resistant
- Highly resistant to acid and solvents
- Free of silicone, cadmium, halogen
- Flame retardant, self-extinguishing
- UV-resistant



RORHflex® PA6 Conduit

Part number	Conduit size	Outer Ø mm	Inner Ø mm	Coil length mtrs
0233.202.010	M12	13.0	10.0	50m
0233.202.012	M16	15.8	12.0	50m
0233.202.016	M20	21.2	16.5	50m
0233.202.023	M25	28.5	23.0	50m
0233.202.029	M32	34.5	29.0	25m
0233.202.036	M40	42.5	36.0	25m
0233.202.048	M50	54.5	48.0	25m

FLEXAquick fittings - no assembly tools required!

RQG1-M (Straight - IP 66)

Part number	For conduit size	Thread size	Pack qty
5020.055.214	M12	M16	50
5020.055.216	M16	M16	50
5020.055.218	M16	M20	50
5020.055.220	M20	M20	50
5020.055.222	M20	M25	50
5020.055.225	M25	M25	25
5020.055.228	M25	M32	25
5020.055.232	M30	M32	25
5020.055.240	M40	M40	25
5020.055.250	M50	M50	10



Mounting clip - RQS (One piece clamp)

Part number	For conduit size	Pack qty
5030.020.209	M12	50
5030.020.211	M16	50
5030.020.216	M20	25
5030.020.221	M25	25
5030.020.229	M32	25
5030.020.236	M40	25
5030.020.248	M50	10



Part number For conduit size Thread size Pack qty

Part number	For conduit size	Thread size	Pack qty
RQW1-M (IP 65)			
5020.051.212	M12	M12	50
5020.051.218	M16	M16	50
5020.051.222	M20	M20	50
RQB90-M (90° Bend - IP 67)			
5103.013.216	M16	M12	50
5103.015.220	M16	M20	50
5103.021.220	M20	M20	50
5103.028.225	M25	M25	25
5103.034.232	M32	M32	25
5103.042.240	M40	M40	10
5103.054.250	M50	M50	5
RQB1 45-M (45° Bend - IP 65)			
5101.013.216	M16	M12	50
5101.021.220	M20	M20	50
5101.042.240	M 40	M 40	10



Locknuts to suit fittings

Part number	Thread size	Pack qty
5311 9100	M12	100
5311 9110	M16	100
5311 9120	M20	100
5311 9130	M25	100



Other industrial conduit types also available

